

# Microcontroller based Solar Tracker System (STS)

Mr. Rikhith Swargiary<sup>1</sup>, Miss Anamika Talukdar<sup>2</sup> and Mr. Pankaj Borah<sup>3</sup>

<sup>1</sup>Post Graduate Student Tripura University

<sup>2</sup>Post Graduate Student Jorhat Engineering College

<sup>3</sup>Jorhat Institute of Science and Technology

E-mail: <sup>1</sup>swargiaryrikhit@gmail.com, <sup>2</sup>onlyforwork24@gmail.com, <sup>3</sup>pankajofcit@gmail.com

---

**Abstract**—In order to trap the energy to the maximum extent solar tracker technique (STT) is used based on the orientation of different payloads toward the sun. Payloads may be photovoltaic cells, reflectors, lenses or other optical devices. For this paper the payload is solar panel and optical device. The tracker detects the sun at dawn and tracks it for the whole day then it resets automatically for the next cycle. Since sunlight basically has two components the direct beam and diffuse sunlight, the direct beam carries about 90% of the solar energy and the diffuse sunlight that carries the remainder. As the majority of the energy is in the direct beam collection of this beam should be Maximum and should fall straight onto the panels as long as possible for which a tracker is needed. The tracker is basically a mechanical device consist of servo motors and moves according to the command from the microcontroller in response to the sun direction. Two light dependent resistors (LDRs) are used as light detector of the sun. This acts as input to the microcontroller. Then according to the program the motor will control the mechanical arrangement in the direction of the movement of the sun.

**Keywords:** STS, STT, LDRs, MPP, MPPT.

## 1. INTRODUCTION

Solar energy is a sustainable and renewable energy which required less maintenance in generating electricity. Once the solar panel have been installed and run at maximum efficiency it maintenance cost is very low. As a result it has good economic benefits at the same time cutting down the harmful emission. In other words creating the use of solar energy seems to be one of the best options available. The usage of solar energy will only provide us with a clean environment, where we will not have to constantly worry about the ever so reducing resources to provide us with the basic comforts of human life [1].

Solar tracker is an automated solar panel that actually follows the Sun to increase the power [2]. Heliostat is one of the solar tracker which is a movable mirror that reflects the moving sun to a fixed location. Active tracker use motor gear trains etc. which are commanded by controllers responding to sun direction [3]. The solar tracker is very useful for device that needs more sunlight for higher efficiency such as solar cell.

In 2011 Asmarashid Ponniranl, et al. focuses on designing of controller whereby it will caused the system is able to tracks

the maximum intensity of Sunlight is hit. When the intensity of Sunlight decreases, the system automatically changes its direction to get maximum intensity of sunlight. LDR acts as light detector sensor. To rotate the appropriate position of the panel, a DC-g geared motor is used by them. The system is controlled by two relays and a microcontroller as a main processor and it was designed for low power applications [4]. In 2013 Dr. Liping Guo, et al. describes the design and simulation of a sun tracking solar power system. The simulation is realized on Matlab/Simulink platform [5]. At the same year Aneesh Kulkarni, et al. presents a photovoltaic system for Solar Position Tracking. Their goal was to design an efficient and cost-effective solar tracking system for small photovoltaic panels, such as those used in domestic applications like water heating based on microcontroller single axis tracking system. Experimental results have demonstrated a marked increase in the average output power for a photovoltaic panel having the tracking system, as compared with an identical fixed-tilted photovoltaic panel [6].

In our work we used LDR (Light Dependent Resistor) as photo sensor element, because LDR is the most sensitive device to detect the light. The resistance of LDR decreases with increase in light intensity. To convert the light into digital form, which is suitable for microcontrollers a sensor circuit is also used. As a controller At89C51 microcontroller is used. The 8051 programming will control the direction of motor. A dc motor is used to rotate the panel in the direction of sun. The motor driver IC L293D supplies the necessary voltage to run the dc motor. Our work can be used where high voltage, current and power rating is required.

The rest of the paper is organized as follows. In section two we discuss regarding solar tracking, and section three discuss working principle, block diagram, DC motor and flow chart, while section four contains result discussion and conclusion. Section five contains conclusion section six and seven finally contain acknowledgement and references.

## 2. SOLAR TRACKING

A solar tracker is a device that orients a payloads towards the sun. Payloads are usually solar panels, parabolic

troughs, fresnel reflectors, mirrors or lenses [7]. Automatic mechanical tracking systems make it possible to track both the azimuth and the elevation of the Sun's position to maximize energy capture. There are different ways of tracking, namely

- **Azimuth Tracking**

Azimuth tracking keeps the collector pointing at the Sun as the Earth rotates. The insulations vary between zero and its maximum value during the course of every day and remains around its maximum value for a relatively short period of time. Azimuth tracking enables the collector to follow the Sun from East to West throughout

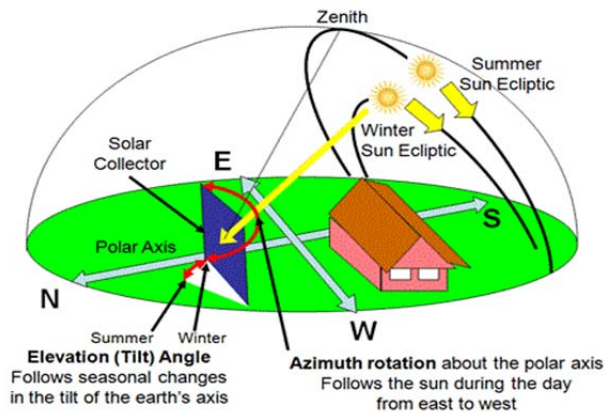

Fig. 1: Solar Tracking [5]

the day and brings the most benefits. Passive systems provide the simplest form of azimuth tracking. They have no motors, controllers or gears and they don't use up any of the energy captured by the collector. They depend on the differential heating of two interconnected tubes of gaseous refrigerants, one on either side of the collector. If the collector is not pointing towards the Sun, one side heats up more than the other and vaporizes its refrigerant. The resulting change in weight is used in a mechanical drive mechanism to turn the collector towards the Sun where it will remain when the temperature and weight of the two tubes will be balanced. Active tracking is also possible by employing temperature sensors and a control system with linear actuating motors taking their drive power from the system.

- **Altitude/Elevation Tracking**

Elevation tracking enables the collector to follow the seasonal variations in the Sun's altitude but the economic benefits are less than for azimuth tracking. Compared with the daily variations in insulations, the seasonal variations are very slow and the range of the variation, due to the solar declination is much more restricted. Because of this, reasonable efficiency gains can be obtained simply by manually adjusting the elevation of the collectors every two months. To avoid the cost and complexity of elevation tracking, it may be more cost effective just to specify larger collectors.

- **Dual Axis Tracking**

Combining azimuth and elevation tracking enables the installation to capture the maximum energy using the smallest possible collectors but the systems are complex and many installations get by with just azimuth tracking [8].

The specification of hardware is one silicon PV module of an open circuit volt of 21V (DC under open-circuit, no-load conditions), short circuit current 3.48 amp and power of 60 watt. The current (and power) output of a PV module depends on its efficiency and size and it is proportional to the intensity of sunlight striking the surface of the cell. Since the latitude of NE is 26 degree the panel is maintained nearly at this angle.

### 3. METHODOLOGY

In project work was divided into two parts, hardware development and programming development. Fig. 2 shows block diagram of the project.

#### 3.1 Block Diagram

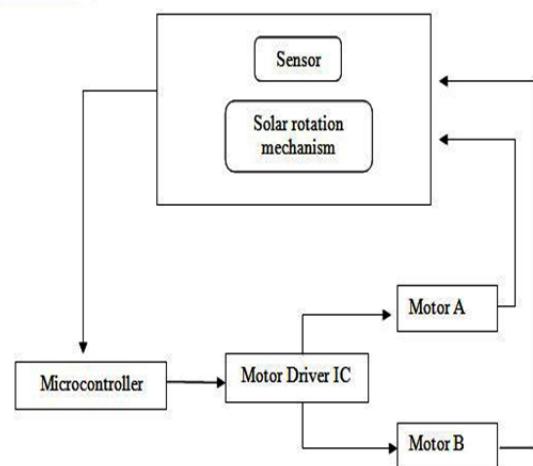

Fig. 2: Block diagram.

The block diagram and circuit diagram in fig 6 shows the utilization of solar tracker circuit to maximize the efficiency of PV cells. It consists of LDR (sensor) attached with the PV panel, microcontroller, driver IC to drive the motor, dc motor and single-axis solar panel mechanism. A sensor circuit is used to convert the light sensed by LDR into digital form which is suitable for microcontroller to read the intensities of sun light at different time. There are two LDR s attached with the PV panel at two different directions east and west respectively. The microcontroller is programmed in such a way that when the east LDR senses the sunlight the motor rotates the whole panel mechanism in the east direction and stops. Again when west LDR senses the sunlight the motor rotates to the west position and stops. Thus this tracker project continuously tracks the sunlight at different position and maximizes the efficiency of PV cells. Again the path of the

sun is different during winter and summer. The panel mechanism can be adjusted according to the path of sun that varies in different seasons manually. The light sensed by the LDRs is converted into digital form to feed it to microcontroller so that it can read the intensities continuously

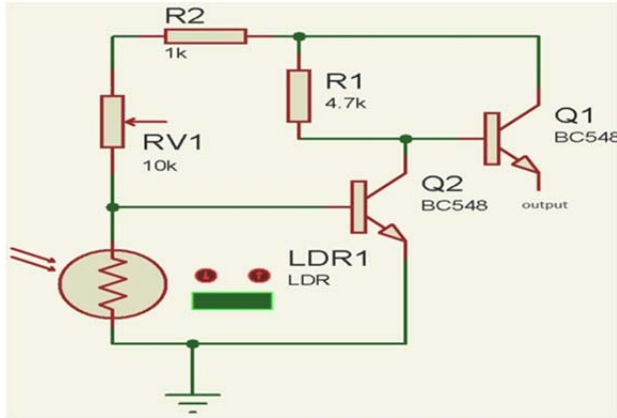

Fig. 3: Sensor Circuit.

The DC output can be fed to a battery for charging it. Thus, using this circuit AC loads and DC loads can be drive with the help of an inverter and a DC/DC converter respectively.

**3.2 DC Motor**

A gear motor is a specific type of electrical motor that is designed to produce high torque while maintaining a low speed motor output or low horsepower motor output. Gear motors which we used in this project are of 30 and 100 RPM. The main working of such type of gear motor is that when it is energized, it rotates in the forward direction and when it is de energized it rotates in the reverse direction. The number of rotation in the forward direction is equal to the number of rotation in the reverse direction. L293D is a motor driver IC which works on the principle of H-bridge. And thus allows DC motor to drive on either direction. L293D IC has 16 pin which can control a set of two DC motors simultaneously in any direction.

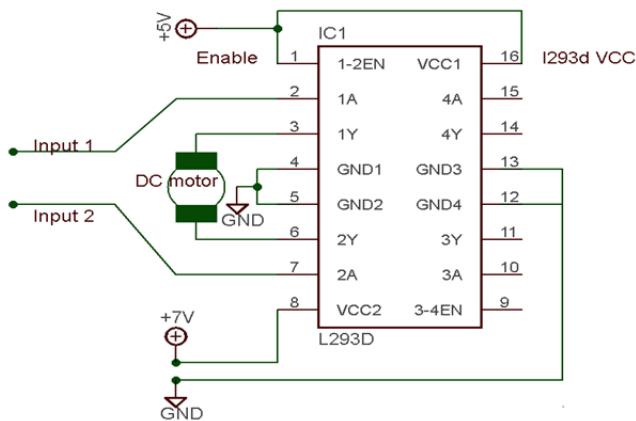

Fig. 4: Circuit diagram of L293D [10]

**L293D Logic Table:**

Let’s consider a Motor connected on left side output pins (pin 3, 6). For rotating the motor in clockwise direction the input pins has to be provided with Logic 1 and Logic 0.

- Pin 2 = Logic 1 and Pin 7 = Logic 0 | Clockwise Direction
- Pin 2 = Logic 0 and Pin 7 = Logic 1 | Anticlockwise Direction
- Pin 2 = Logic 0 and Pin 7 = Logic 0 | Idle [No rotation] [Hi-Impedance state]
- Pin 2 = Logic 1 and Pin 7 = Logic 1 | Idle [No rotation] [10].

**3.3 Flow Chart**

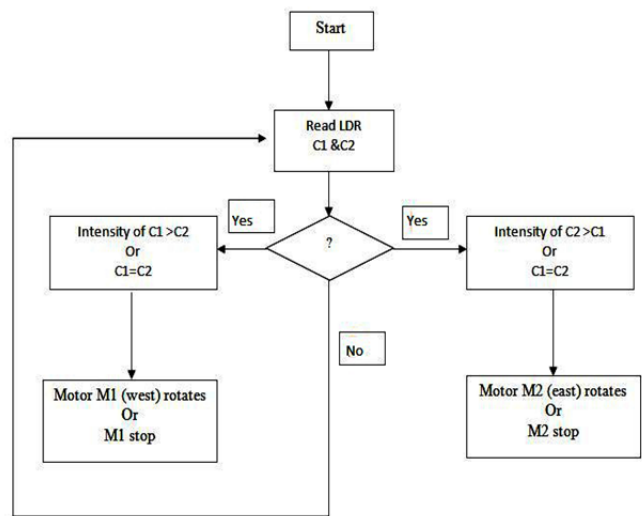

Fig. 5: Flow chart.

**4. RESULT AND DISCUSSION**

Finally, the project on solar tracker shows the best result to maximize the efficiency of PV cells of the solar panel. Due to continuous tracking of sunlight the PV cells can produce the maximum output power. The output signal generated from the microcontroller is first fed to the driver IC L293D to provide the necessary voltage and current rating to the DC motor. This signal from microcontroller controls the direction of motor smoothly. Such a project is suitable for some systems which require high voltage, current and power rating. This whole circuit works to develop the maximum power delivered by the solar panel. This circuit can be also used to produce more voltage using a boost converter.

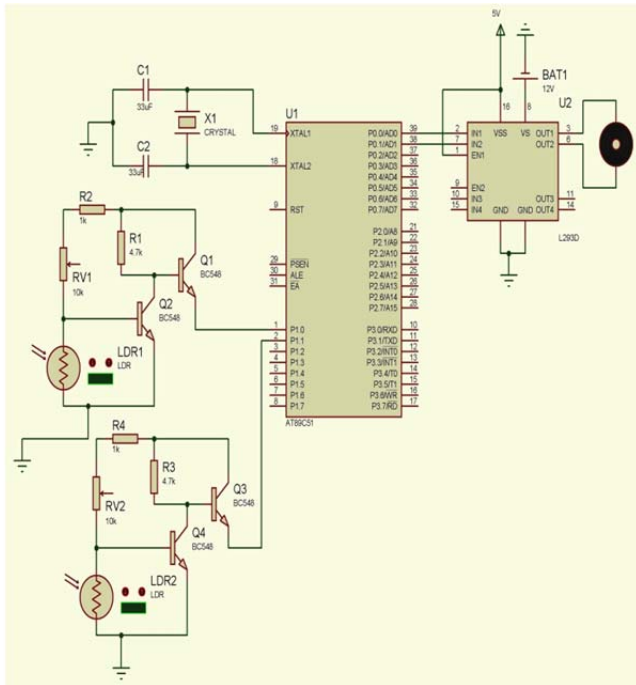

Fig. 6: Overall circuit of proteus

## 5. CONCLUSION

Single axis solar tracking system model is developed this system mainly focuses on designing appropriate circuit of controller that can control the direction of motor. The system is able to track the sunlight intensity in order to collect maximum solar power. The characteristics of this model is that the motor speed is not critical consideration because the DC-gearred motor offers low output rated speed and high output rated torque. Therefore any type of DC motor can be used. Such type of design can be used in various appliances especially where more power rating is necessary.

The device is very effective, high efficiency, good response, continuous tracking the maximum power point (MPP) and offers an algorithm involving simple computations and a single voltage sensor. However appropriate designed of solar tracker mechanism is required based on the size of the solar

panel. The work can be implemented to design vehicle transportation that can reduce more pollution. Also it can be used in solar charger, micro inverter and the plants where high voltage is required. The disadvantage of single axis solar tracking system is mentioned because sun varies its position in the sky with change in season as well as with time of a day. Further work can be carried for development of a high power output using maximum power point tracking MPPT system and design of such device with linear actuator.

## 6. ACKNOWLEDGEMENT

The authors express genuine gratitude to resource persons, educational institute and encouraging people who helped in developing the proposed model.

## REFERENCE:

- [1] <http://solarpowernotes.com/why-solar-energy.html>
- [2] D. Appleyard, "Solar Trackers: Facing the Sun," Renewable Energy World, Vol. 12, No. 3, 2009. <http://www.renewableenergyworld.com/articles/print/volume-12/issue-3/solar-energy/solar-trackers-facing-the-sun.html>
- [3] Asmarashid Ponniran; Ammar Hashim; Handy Ali Munir "A design of single axis\_sun tracking system,"IEEE, 6-7 June 2011.
- [4] Asmarashid Ponniran, Ammar Hashim, Ariffuddin Joret "A Design of Low Power Single Axis Solar Tracking System Regardless of Motor Speed" International Journal of Integrated Engineering, Vol. 3 No. 3 (2011).
- [5] A. W. O. Guo Liping, Jingbo Han, "Design and simulation of a sun tracking solar power system," in 120th ASEE Annual Conference and Exposition.
- [6] Aneesh Kulkarni, Tushar Kshirsagar, Akash Laturia, P. H. Ghare, "An Intelligent Solar Tracker for Photovoltaic Panels," IEEE 2013.
- [7] [https://en.wikipedia.org/wiki/Solar\\_tracker](https://en.wikipedia.org/wiki/Solar_tracker)
- [8] Battery and Energy Technologies- Solar Tracking. [http://www.mpoweruk.com/solar\\_power.htm](http://www.mpoweruk.com/solar_power.htm)
- [9] Photo Detector circuit <http://www.sciencehq.com/infos/photo-detector-circuit.html>
- [10] Ron Robotics- L293D Motor Driver IC
- [11] <http://www.rakeshmondal.info/L293D-Motor-Driver>